



### A Level Syllabus and Assessment Structure:

At LRGS, students follow the AQA A level Chemistry specification (GCE Chemistry 7405)

<http://www.aqa.org.uk/subjects/science/as-and-a-level/chemistry-7404-7405/specification-at-a-glance>

Paper 1	+	Paper 2	+	Paper 3
<b>What's assessed</b> <ul style="list-style-type: none"> <li>Relevant Physical chemistry topics (sections 3.1.1 to 3.1.4, 3.1.6 to 3.1.8 and 3.1.10 to 3.1.12)</li> <li>Inorganic chemistry (Section 3.2)</li> <li>Relevant practical skills</li> </ul>		<b>What's assessed</b> <ul style="list-style-type: none"> <li>Relevant Physical chemistry topics (sections 3.1.2 to 3.1.6 and 3.1.9)</li> <li>Organic chemistry (Section 3.3)</li> <li>Relevant practical skills</li> </ul>		<b>What's assessed</b> <ul style="list-style-type: none"> <li>Any content</li> <li>Any practical skills</li> </ul>
<b>How it's assessed</b> <ul style="list-style-type: none"> <li>written exam: 2 hours</li> <li>105 marks</li> <li>35% of A-level</li> </ul>		<b>How it's assessed</b> <ul style="list-style-type: none"> <li>written exam: 2 hours</li> <li>105 marks</li> <li>35% of A-level</li> </ul>		<b>How it's assessed</b> <ul style="list-style-type: none"> <li>written exam: 2 hours</li> <li>90 marks</li> <li>30% of A-level</li> </ul>
<b>Questions</b> 105 marks of short and long answer questions		<b>Questions</b> 105 marks of short and long answer questions		<b>Questions</b> 40 marks of questions on practical techniques and data analysis  20 marks of questions testing across the specification  30 marks of multiple choice questions

A separate endorsement of practical skills will be completed alongside the A-level. This will be assessed by your teachers and will be based on direct observation of students' competency in a range of skills that are not assessable in written exams.

Required (Task Time: )	N/A.
Highly Recommended (Task Time: 2 hours)	Read through the Chemistry A-level Transition booklet and answer all of the questions in it. This is based on material that should be familiar from GCSE.

# A LEVEL ESSENTIALS

Name ..... Form .....

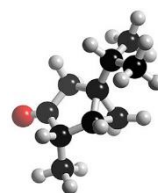

## Chemistry at LRGS – What to Expect

At LRGS we sit the AQA A level Chemistry specification (GCE Chemistry 7405)

<http://www.aqa.org.uk/subjects/science/as-and-a-level/chemistry-7404-7405/specification-at-a-glance>

Paper 1	+	Paper 2	+	Paper 3
<b>What's assessed</b> <ul style="list-style-type: none"><li>• Relevant Physical chemistry topics (sections 3.1.1 to 3.1.4, 3.1.6 to 3.1.8 and 3.1.10 to 3.1.12)</li><li>• Inorganic chemistry (Section 3.2)</li><li>• Relevant practical skills</li></ul>		<b>What's assessed</b> <ul style="list-style-type: none"><li>• Relevant Physical chemistry topics (sections 3.1.2 to 3.1.6 and 3.1.9)</li><li>• Organic chemistry (Section 3.3)</li><li>• Relevant practical skills</li></ul>		<b>What's assessed</b> <ul style="list-style-type: none"><li>• Any content</li><li>• Any practical skills</li></ul>
<b>How it's assessed</b> <ul style="list-style-type: none"><li>• written exam: 2 hours</li><li>• 105 marks</li><li>• 35% of A-level</li></ul>		<b>How it's assessed</b> <ul style="list-style-type: none"><li>• written exam: 2 hours</li><li>• 105 marks</li><li>• 35% of A-level</li></ul>		<b>How it's assessed</b> <ul style="list-style-type: none"><li>• written exam: 2 hours</li><li>• 90 marks</li><li>• 30% of A-level</li></ul>
<b>Questions</b> <p>105 marks of short and long answer questions</p>		<b>Questions</b> <p>105 marks of short and long answer questions</p>		<b>Questions</b> <p>40 marks of questions on practical techniques and data analysis</p> <p>20 marks of questions testing across the specification</p> <p>30 marks of multiple choice questions</p>

## Topics

### 3.1 Physical chemistry

- 3.1.1 Atomic structure
- 3.1.2 Amount of substance
- 3.1.3 Bonding
- 3.1.4 Energetics
- 3.1.5 Kinetics
- 3.1.6 Chemical equilibria, Le Chatelier's principle and  $K_c$
- 3.1.7 Oxidation, reduction and redox equations
- 3.1.8 Thermodynamics (A-level only)
- 3.1.9 Rate equations (A-level only)
- 3.1.10 Equilibrium constant  $K_p$  for homogeneous systems (A-level only)
- 3.1.11 Electrode potentials and electrochemical cells (A-level only)
- 3.1.12 Acids and bases (A-level only)

### 3.2 Inorganic chemistry

- 3.2.1 Periodicity
- 3.2.2 Group 2, the alkaline earth metals
- 3.2.3 Group 7(17), the halogens
- 3.2.4 Properties of Period 3 elements and their oxides (A-level only)
- 3.2.5 Transition metals (A-level only)
- 3.2.6 Reactions of ions in aqueous solution (A-level only)

### 3.3 Organic chemistry

- 3.3.1 Introduction to organic chemistry
- 3.3.2 Alkanes
- 3.3.3 Halogenoalkanes
- 3.3.4 Alkenes
- 3.3.5 Alcohols
- 3.3.6 Organic analysis
- 3.3.7 Optical isomerism (A-level only)
- 3.3.8 Aldehydes and ketones (A-level only)
- 3.3.9 Carboxylic acids and derivatives (A-level only)
- 3.3.10 Aromatic chemistry (A-level only)
- 3.3.11 Amines (A-level only)
- 3.3.12 Polymers (A-level only)
- 3.3.13 Amino acids, proteins and DNA (A-level only)
- 3.3.14 Organic synthesis (A-level only)
- 3.3.15 Nuclear magnetic resonance spectroscopy (A-level only)
- 3.3.16 Chromatography (A-level only)

## What is expected from you?

Equipment: You will need a well organised file (there will be checks) and must bring a calculator and Periodic Table to every Chemistry lesson.

Hard work: You need to work extremely hard to be successful at A-level Chemistry. It is expected that you will **review your work** as a matter of course after every lesson, in addition to **reading the relevant section** in a textbook. There will be written work set in addition to this.

Independent study: The resources library is available for quiet study and the Chemistry teachers are always willing to answer queries at any time. There is a wealth of web-based resources. You will also have access to an online textbook through the Kerboodle website.

## Basic units to know:

Physical Quantity	Name of unit	Symbol
Mass	kilogram	kg
Thermodynamic temperature	kelvin	K (not °K)
Amount of substance	mole	mol
Pressure	Newton per metre squared (pascal)	Nm <sup>-2</sup> (Pa)
Specific heat capacity	joule per kilogram kelvin	Jkg <sup>-1</sup> K <sup>-1</sup>
Concentration (molarity)	mol per decimetre cubed	mol dm <sup>-3</sup> (M)

## Some Important Physical Constants

Gas constant (R) 8.314 Jkg<sup>-1</sup>K<sup>-1</sup>  
Specific heat capacity of water 4.2 Jg<sup>-1</sup>K<sup>-1</sup>

## Useful Conversions

1 atmosphere = 101325 Nm<sup>-2</sup> (Pa)  
1 litre (l) is equivalent to 1dm<sup>3</sup>  
1dm<sup>3</sup> = 10<sup>-3</sup>m<sup>3</sup>  
1cm<sup>3</sup> = 10<sup>-3</sup>dm<sup>3</sup> = 10<sup>-6</sup>m<sup>3</sup>  
0°C = 273K

## Some important chemicals to know

Hydrochloric acid HCl  
Sulphuric acid H<sub>2</sub>SO<sub>4</sub>  
Nitric acid HNO<sub>3</sub>  
Sodium hydroxide NaOH  
Ammonia NH<sub>3</sub>

## Formulae of Ionic Compounds

Ions are charged particles. Ions with a positive charge are known as **cations** and ions with a negative charge are known as **anions**. The formula of an ionic compound is the formula which shows the simplest whole number ratio in which the ions in the compound exist. This depends on the charges of the ions involved.

Some important ions and their charges are shown below. The ions in bold are compound ions.

1	hydrogen sodium potassium lithium rubidium caesium copper(I) silver(I) <b>ammonium</b>	H <sup>+</sup> Na <sup>+</sup> K <sup>+</sup> Li <sup>+</sup> Rb <sup>+</sup> Cs <sup>+</sup> Cu <sup>+</sup> Ag <sup>+</sup> <b>NH<sub>4</sub><sup>+</sup></b>	chloride bromide iodide <b>hydroxide</b> <b>nitrate</b> <b>nitrite</b> <b>hydrogencarbonate</b> <b>hydrogensulfate</b>	Cl <sup>-</sup> Br <sup>-</sup> I <sup>-</sup> <b>OH<sup>-</sup></b> <b>NO<sub>3</sub><sup>-</sup></b> <b>NO<sub>2</sub><sup>-</sup></b> <b>HCO<sub>3</sub><sup>-</sup></b> <b>HSO<sub>4</sub><sup>-</sup></b>
2	calcium barium magnesium zinc iron(II) cobalt(II) manganese(II) copper(II)	Ca <sup>2+</sup> Ba <sup>2+</sup> Mg <sup>2+</sup> Zn <sup>2+</sup> Fe <sup>2+</sup> Co <sup>2+</sup> Mn <sup>2+</sup> Cu <sup>2+</sup>	<b>sulfate</b> <b>sulfite</b> sulfide oxide <b>carbonate</b>	<b>SO<sub>4</sub><sup>2-</sup></b> <b>SO<sub>3</sub><sup>2-</sup></b> S <sup>2-</sup> O <sup>2-</sup> <b>CO<sub>3</sub><sup>2-</sup></b>
3	aluminium iron(III)	Al <sup>3+</sup> Fe <sup>3+</sup>	<b>phosphate</b>	<b>PO<sub>4</sub><sup>3-</sup></b>

Work out the formula for each of these compounds:

- 1) Potassium iodide
- 2) potassium sulfate
- 3) sodium oxide
- 4) magnesium sulfate
- 5) aluminium bromide
- 6) magnesium hydroxide
- 7) magnesium chloride
- 8) copper(II) nitrate
- 9) zinc carbonate
- 10) iron(II) oxide
- 11) potassium hydroxide
- 12) iron(III)oxide
- 13) sodium carbonate
- 14) calcium sulfide
- 15) aluminium hydroxide
- 16) copper(II) chloride
- 17) aluminium iodide
- 18) lithium fluoride
- 19) ammonium chloride
- 20) barium chloride
- 21) ammonium hydroxide
- 22) lead(II) sulfide
- 23) iron(III) nitrate
- 24) zinc iodide
- 25) zinc chloride
- 26) aluminium sulfide
- 27) potassium oxide
- 28) barium oxide
- 29) potassium nitrate
- 30) silver bromide
- 31) lithium sulfide
- 32) iron(III) fluoride
- 33) potassium carbonate
- 34) calcium nitrate
- 35) ammonium sulfate
- 36) ammonium hydroxide

# A LEVEL ESSENTIALS – ionic equations

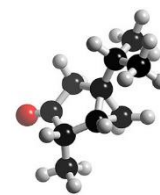

Name ..... Form .....

Many reactions that take place in aqueous solution do not involve all of the ions that are written in the equation. Some species remain in aqueous solution before and after the reaction. They therefore play no part in the reaction and are known as **spectator ions**.

In **ionic equations**, spectator ions are left out.

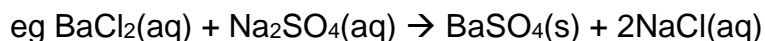

This reaction involves the precipitation of barium sulfate.

Notice that the  $\text{Cl}^-$  ions and the  $\text{Na}^+$  ions remain in the aqueous state before and after the reaction. They are therefore spectator ions.

The above reaction can then be rewritten as follows:

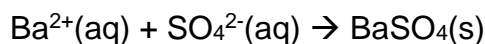

Ionic equations are very useful for simplifying **precipitation** reactions (when a solid is formed from two solutions).

They can also simplify **acid-base** reactions:

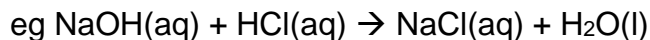

The  $\text{Na}^+$  and  $\text{Cl}^-$  ions are spectator ions, so the ionic equation for the reaction is:

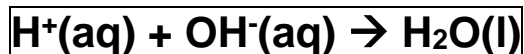

All reactions between strong acids and strong alkalis have the same ionic equation.

## Visual Example

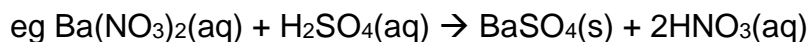

Ionic Equation:

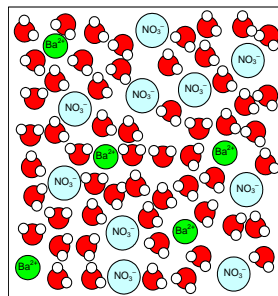
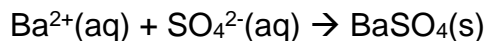

$\text{Ba}(\text{NO}_3)_2(\text{aq})$

+

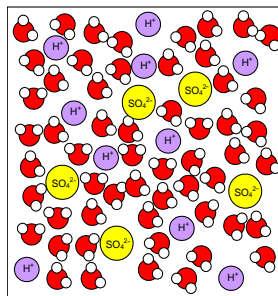

$\text{H}_2\text{SO}_4(\text{aq})$

→

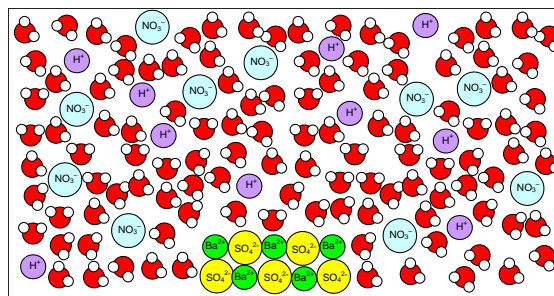

Reaction takes place:  $\text{Ba}^{2+}(\text{aq}) + \text{SO}_4^{2-}(\text{aq}) \rightarrow \text{BaSO}_4(\text{s})$

Some general reactions you should know:

General Reaction	Examples
substance + oxygen $\rightarrow$ oxides	$2 \text{Mg} + \text{O}_2 \rightarrow 2 \text{MgO}$ $2 \text{H}_2\text{S} + 3 \text{O}_2 \rightarrow 2 \text{H}_2\text{O} + 2 \text{SO}_2$ $\text{C}_3\text{H}_8 + 5 \text{O}_2 \rightarrow 3 \text{CO}_2 + 4 \text{H}_2\text{O}$
metal + water $\rightarrow$ metal hydroxide + hydrogen	$2 \text{Na} + 2 \text{H}_2\text{O} \rightarrow 2 \text{NaOH} + \text{H}_2$
metal + acid $\rightarrow$ salt + hydrogen	$\text{Mg} + 2 \text{HCl} \rightarrow \text{MgCl}_2 + \text{H}_2$
oxide + acid $\rightarrow$ salt + water	$\text{MgO} + 2 \text{HNO}_3 \rightarrow \text{Mg}(\text{NO}_3)_2 + \text{H}_2\text{O}$
hydroxide + acid $\rightarrow$ salt + water	$2 \text{NaOH} + \text{H}_2\text{SO}_4 \rightarrow \text{Na}_2\text{SO}_4 + \text{H}_2\text{O}$
carbonate + acid $\rightarrow$ salt + water + carbon dioxide	$\text{CuCO}_3 + 2 \text{HCl} \rightarrow \text{CuCl}_2 + \text{H}_2\text{O} + \text{CO}_2$
hydrogencarbonate + acid $\rightarrow$ salt + water + carbon dioxide	$\text{KHCO}_3 + \text{HCl} \rightarrow \text{KCl} + \text{H}_2\text{O} + \text{CO}_2$
ammonia + acid $\rightarrow$ ammonium salt	$\text{NH}_3 + \text{HCl} \rightarrow \text{NH}_4\text{Cl}$
metal carbonate $\rightarrow$ metal oxide + carbon dioxide (on heating)	$\text{CaCO}_3 \rightarrow \text{CaO} + \text{CO}_2$

1) Balance the following equations.

- $\text{Mg} + \text{HNO}_3 \rightarrow \text{Mg}(\text{NO}_3)_2 + \text{H}_2$
- $\text{CuCl}_2 + \text{NaOH} \rightarrow \text{Cu}(\text{OH})_2 + \text{NaCl}$
- $\text{SO}_2 + \text{O}_2 \rightarrow \text{SO}_3$
- $\text{C}_4\text{H}_{10} + \text{O}_2 \rightarrow \text{CO}_2 + \text{H}_2\text{O}$

2) Give balanced equations for the following reactions.

- sodium + oxygen  $\rightarrow$  sodium oxide
- aluminium + chlorine  $\rightarrow$  aluminium chloride
- calcium + hydrochloric acid  $\rightarrow$  calcium chloride + hydrogen

## State Symbols

- (s) - solid
- (l) - liquid
- (g) - gas
- (aq) – aqueous (dissolved in water)
- (alc) – alcoholic solution (dissolved in alcohol)

<p>Optional (Task Time: 5 hours)</p>	<p>The progression activities booklet from AQA provides information about:</p> <ul style="list-style-type: none"> <li>• the specification and structure of the assessment</li> <li>• key skills activities to support the move from GCSE to A-level Chemistry.</li> </ul> <p>The answers can be found <a href="#">here</a>.</p>
<p>Optional</p>	<p>If you are looking for something to drive your interest forward, broaden and extend your knowledge of the subject (or even just to entertain you), there are a many excellent Chemistry-related books available.</p> <p>Here are some that are all approachable and you could dip into a few of them.</p> <p>The Periodic Table - Primo Levi  The Chemical History of a Candle - Michael Faraday  Molecules of Murder - John Emsley  The Disappearing Spoon - Sam Kean  Mauve - Simon Garfield  Uncle Tungsten - Oliver Sacks  Headstrong: 52 Women Who Changed Science and the World – Rachel Swaby  Quantum: A Guide for the Perplexed - Jim Al-Khalili  Pathfinders: The Golden Age Of Arabic Science - Jim Al-Khalili  Stuff Matters – Mark Miodownik  There Is No Planet B – Mike Berners-Lee  How Bad are Bananas? – Mike Berners-Lee</p>

# GCSE to A-level progression: Student transition activities – Chemistry

---

Student booklet with information about:

- the specification and structure of the assessment
- and key skills activities to support the move from GCSE to A-level Chemistry.

Published: November 2020

Contents	Page
Understanding the specification and the assessment	3-8
Transition activity 1-3 Scientific vocabulary	10-12
Transition activity 4 SI units and prefixes	14
Transition activity 5 Converting data	15
Transition activity 6 Using the delta symbol	16
Transition activity 7 Practical skills: Electrolysis	17-19
Transition activity 8 Using maths skills	20-21
Transition activity 9 Atoms	23
Transition activity 10 Formulae of common compounds	23
Transition activity 11 Ions and ionic compounds	24
Transition activity 12 Empirical formula	25
Transition activity 13 Balancing equations	26
Transition activity 14 Moles	27
Transition activity 15 Isotopes and calculating relative atomic mass	27
Transition activity 16 Extended writing: Types of bonding	28

## Aim of the booklet

This booklet will support your transition from GCSE science to A-level. At first, you may find the jump in demand a little daunting, but if you follow the tips and advice in this guide, you'll soon adapt. As you follow the course you will see how the skills and content you learnt at GCSE will be developed and your knowledge and understanding of all these elements will progress.

We have organised the guide into two sections:

1. Understanding the specification and the assessments
2. Transition activities to bridge the move from GCSE to the start of the A-level course.

## Understanding the specification and the assessments

### Specification at a glance

The specification is a useful reference document for you. You can download a copy from our website [here](#).

The most relevant areas of the specification for students are the following:

- Section 3: Subject content
- Section 6: Maths requirements and examples
- Section 7: Practical assessment

In Chemistry the subject content is split into three broad areas:

- 3.1 Physical chemistry
- 3.2 Inorganic chemistry
- 3.3 Organic chemistry

There are several sections within each of these broad areas. The content of each of these three broad areas is then split between AS and A-level.

The split of content between AS and A-level is shown in the tables below.

## Content common to AS and A-level

3.1 Physical chemistry	3.2 Inorganic chemistry	3.3 Organic chemistry
3.1.1 Atomic structure	3.2.1 Periodicity	3.3.1 Introduction to organic chemistry
3.1.2 Amount of substance	3.2.2 Group 2, the alkaline earth metals	3.3.2 Alkanes
3.1.3 Bonding	3.2.3 Group 7(17), the halogens	3.3.3 Halogenoalkanes
3.1.4 Energetics		3.3.4 Alkenes
3.1.5 Kinetics		3.3.5 Alcohols
3.1.6 Chemical equilibrium, Le Chatelier's principle and $K_c$		3.3.6 Organic analysis
3.1.7 Oxidation, reduction and redox equations		

## A-level only content

3.1 Physical chemistry	3.2 Inorganic chemistry	3.3 Organic chemistry
3.1.8 Thermodynamics	3.2.4 Properties of Period 3 elements and their oxides	3.3.7 Optical isomerism
3.1.9 Rates of equations	3.2.5 Transition metals	3.3.8 Aldehydes and ketones
3.1.10 Equilibrium constant $K_p$ for homogeneous systems	3.2.6 Reactions of ions in aqueous solution	3.3.9 Carboxylic acids and derivatives
3.1.11 Electrode potentials and electrochemical cells		3.3.10 Aromatic chemistry
3.1.12 Acids and bases		3.3.11 Amines
		3.3.12 Polymers
		3.3.13 Amino acids, proteins and DNA
		3.3.14 Organic synthesis
		3.3.15 Nuclear magnetic resonance spectroscopy
		3.3.16 Chromatography

Each section of the content begins with an overview, which describes the broader context and encourages an understanding of the place each section has within the subject. This overview will not be directly assessed.

The specification is presented in a two-column format:

- the left-hand column contains the specification content that you must cover, and that can be assessed in the written papers.
- the right-hand column exemplifies the opportunities for maths and practical skills to be developed throughout the course. These skills can be assessed through any of the content on the written papers, not necessarily in the topics we have signposted.

## Assessment structure

### AS

The assessment for the AS consists of two exams, which you will take at the end of the course.

Paper 1	+	Paper 2
<b>What's assessed</b> <ul style="list-style-type: none"><li>• Relevant Physical chemistry topics (sections 3.1.1 to 3.1.4, 3.1.6 and 3.1.7)</li><li>• Inorganic chemistry (Section 3.2.1 to 3.2.3)</li><li>• Relevant practical skills</li></ul>		<b>What's assessed</b> <ul style="list-style-type: none"><li>• Relevant Physical chemistry topics (sections 3.1.2 to 3.1.6)</li><li>• Organic chemistry (Section 3.3.1 to 3.3.6)</li><li>• Relevant practical skills</li></ul>
<b>How it's assessed</b> <ul style="list-style-type: none"><li>• Written exam: 1 hour 30 mins</li><li>• 80 marks</li><li>• 50% of the AS</li></ul>		<b>How it's assessed</b> <ul style="list-style-type: none"><li>• Written exam: 1 hour 30 mins</li><li>• 80 marks</li><li>• 50% of the AS</li></ul>
<b>Questions</b> <ul style="list-style-type: none"><li>• 65 marks of short and long answer questions</li><li>• 15 marks of multiple choice questions</li></ul>		<b>Questions</b> <ul style="list-style-type: none"><li>• 65 marks of short and long answer questions</li><li>• 15 marks of multiple choice questions</li></ul>

## A-level

The assessment for the A-level consists of three exams, which you will take at the end of the course.

Paper 1	Paper 2	Paper 3
<b>What's assessed</b> <ul style="list-style-type: none"><li>• Relevant Physical chemistry topics (sections 3.1.1 to 3.1.4, 3.1.6 to 3.1.8 and 3.1.10 to 3.1.12)</li><li>• Inorganic chemistry (Section 3.2)</li><li>• Relevant practical skills</li></ul>	<b>What's assessed</b> <ul style="list-style-type: none"><li>• Relevant Physical chemistry topics (sections 3.1.2 to 3.1.6 and 3.1.9)</li><li>• Organic chemistry (Section 3.3)</li><li>• Relevant practical skills</li></ul>	<b>What's assessed</b> <ul style="list-style-type: none"><li>• Any content</li><li>• Any practical skills</li></ul>
<b>How it's assessed</b> <ul style="list-style-type: none"><li>• Written exam: 2 hours</li><li>• 105 marks</li><li>• 35% of the A-level</li></ul>	<b>How it's assessed</b> <ul style="list-style-type: none"><li>• Written exam: 2 hours</li><li>• 105 marks</li><li>• 35% of the A-level</li></ul>	<b>How it's assessed</b> <ul style="list-style-type: none"><li>• Written exam: 2 hours</li><li>• 90 marks</li><li>• 30% of the A-level</li></ul>
<b>Questions</b> <ul style="list-style-type: none"><li>• 105 marks of long and short answer questions</li></ul>	<b>Questions</b> <ul style="list-style-type: none"><li>• 105 marks of short and long answer questions.</li></ul>	<b>Questions</b> <ul style="list-style-type: none"><li>• 40 marks of questions on practical techniques and data analysis</li><li>• 20 marks of questions testing across the specification</li><li>• 30 marks of multiple choice questions</li></ul>

## Assessment objectives

As you know from GCSE, we have to write exam questions that address the Assessment objectives (AOs). It is important you understand what these AOs are, so you are well prepared. In Chemistry there are three AOs.

- AO1: Demonstrate knowledge and understanding of scientific ideas, processes, techniques, and procedures (A-level about 30% of the marks).
- AO2: Apply knowledge and understanding of scientific ideas, processes, techniques, and procedures:
  - in a theoretical context
  - in a practical context
  - when handling qualitative data
  - when handling quantitative data(A-level about 45% of the marks).
- AO3: Analyse, interpret, and evaluate scientific information, ideas, and evidence, including in relation to:
  - make judgements and reach conclusions
  - develop and refine practical design and procedures(A-level about 25% of the marks).

## Other assessment criteria

At least 20% of the marks for AS and A-level Chemistry will assess mathematical skills, which will be equivalent to Level 2 (Higher Tier GCSE Mathematics) or above.

At least 15% of the overall assessment of AS and A-level Chemistry will assess knowledge, skills and understanding in relation to practical work.

## Command words

Command words are used in questions to tell you what is required when answering the question. You can find definitions of the command words used in chemistry assessments on the [website](#). They are very similar to the command words used at GCSE.

## Subject-specific vocabulary

You can find a list of definitions of key working scientifically terms used in our AS and A-level specification [here](#).

You will become familiar with, and gain understanding of, these terms as you work through the course.

## Transition activities

The following activities cover some of the key skills from GCSE science that will be relevant at AS and A-level. They include the vocabulary used when working scientifically and some maths and practical skills.

You can do these activities independently or in class. The booklet has been produced so you can complete it electronically or print it out and do the activities on paper.

The activities are **not a test**. Try the activities first and see what you remember and then use textbooks or other resources to answer the questions. **Don't** just go to Google for the answers, as actively engaging with your notes and resources from GCSE will make this learning experience much more worthwhile.

The answer booklet guides you through each answer. It is not set out like an exam mark scheme but is to help you get the most out of the activities.

## Understanding and using scientific vocabulary

Understanding and applying the correct terms are key for practical science. Much of the vocabulary you have used at GCSE for practical work will not change but some terms are dealt with in more detail at A-level so are more complex.

## Activity 1 Scientific vocabulary: Designing an investigation

Link each term on the left to the correct definition on the right.

Hypothesis

The maximum and minimum values of the independent or dependent variable

Dependent variable

A variable that is kept constant during an experiment

Independent variable

The quantity between readings, eg a set of 11 readings equally spaced over a distance of 1 metre would give an interval of 10 centimetres

Control variable

A proposal intended to explain certain facts or observations

Range

A variable that is measured as the outcome of an experiment

Interval

A variable selected by the investigator and whose values are changed during the investigation

## Activity 2 Scientific vocabulary: Making measurements

Link each term on the left to the correct definition on the right.

True value

The range within which you would expect the true value to lie

Accurate

A measurement that is close to the true value

Resolution

Repeated measurements that are very similar to the calculated mean value

Precise

The value that would be obtained in an ideal measurement where there were no errors of any kind

Uncertainty

The smallest change that can be measured using the measuring instrument that gives a readable change in the reading

### Activity 3 Scientific vocabulary: Errors

Link each term on the left to the correct definition on the right.

Random error

Causes readings to differ from the true value by a consistent amount each time a measurement is made

Systematic error

When there is an indication that a measuring system gives a false reading when the true value of a measured quantity is zero

Zero error

Causes readings to be spread about the true value, due to results varying in an unpredictable way from one measurement to the next

### Understanding and using SI units

Every measurement has a size (eg 2.7) and a unit (eg metres or kilograms). Sometimes, there are different units available for the same type of measurement. For example, milligram, gram, kilogram and tonne are all units used for mass.

There is a standard system of units, called the SI units, which are used for most scientific purposes.

These units have all been defined by experiment so that the size of, say, a metre in the UK is the same as a metre in China.

There are seven SI base units, which are given in the table.

Physical quantity	Unit	Abbreviation
Mass	kilogram	kg
Length	metre	m
Time	second	s
Electric current	ampere	A
Temperature	kelvin	K
Amount of substance	mole	mol
luminous intensity	candela	cd

All other units can be derived from the SI base units. For example, area is measured in metres square (written as  $m^2$ ) and speed is measured in metres per second

(written as  $\text{m s}^{-1}$ : not that this is a change from GCSE, where it would be written as  $\text{m/s}$ ).

## Using prefixes and powers of ten

Very large and very small numbers can be complicated to work with if written out in full with their SI unit. For example, measuring the width of a hair or the distance from Manchester to London in metres (the SI unit for length) would give numbers with a lot of zeros before or after the decimal point, which would be difficult to work with.

So, we use prefixes that multiply or divide the numbers by different powers of ten to give numbers that are easier to work with. You will be familiar with the prefixes milli (meaning  $1/1000$ ), centi ( $1/100$ ), and kilo ( $1 \times 1000$ ) from millimetres, centimetres and kilometres.

There is a wide range of prefixes. Most of the quantities in scientific contexts will be quoted using the prefixes that are multiples of 1000. For example, we would quote a distance of 33 000 m as 33 km.

The most common prefixes you will encounter are given in the table.

Prefix	Symbol	Power of 10	Multiplication factor	
Tera	T	$10^{12}$	1 000 000 000 000	
Giga	G	$10^9$	1 000 000 000	
Mega	M	$10^6$	1 000 000	
kilo	k	$10^3$	1000	
deci	d	$10^{-1}$	0.1	1/10
centi	c	$10^{-2}$	0.01	1/100
milli	m	$10^{-3}$	0.001	1/1000
micro	$\mu$	$10^{-6}$	0.000 001	1/1 000 000
nano	n	$10^{-9}$	0.000 000 001	1/1 000 000 000
pico	p	$10^{-12}$	0.000 000 000 001	1/1 000 000 000 000
femto	f	$10^{-15}$	0.000 000 000 000 001	1/1 000 000 000 000 000

#### Activity 4 SI units and prefixes

1. What would be the most appropriate unit to use for the following measurements?

- a. The mass of water in a test tube.
- b. The volume of water in a burette.
- c. The time taken for a solution to change colour.
- d. The radius of a gold atom.
- e. The number of particles eg atoms in a chemical.
- f. The temperature of a liquid.

2. Re-write the following quantities using the correct SI units.

- a. 0.5 litres
- b. 5 minutes
- c. 20 °C
- d. 70 °F
- e. 10 ml (millilitres)
- f. 5.5 tonnes
- g. 96.4 microlitres ( $\mu\text{l}$ )

3. Scientists have been developing the production of a new material through the reaction of two constituents.

Before going to commercial production, the scientists must give their data in the correct SI units.

- a. The flow rate of the critical chemical was reported as 240 grams per minute at a temperature of 20 °C.

Re-write this flow rate using the correct SI units. Show your working.

### Activity 5 Converting data

Re-write the following.

1. 0.1 metres in millimetres
2. 1 centimetre in millimetres
3. 104 micrograms in grams
4. 1.1202 kilometres in metres
5. 70 decilitres in millilitres
6. 70 decilitres in litres
7.  $10 \text{ cm}^3$  in litres
8. 2140 pascals in kilopascals

## The delta symbol ( $\Delta$ )

The delta symbol ( $\Delta$ ) is used to mean 'change in'. You might not have seen this symbol before in your GCSE Chemistry course, although it is used in some equations in GCSE Physics.

### Activity 6 Using the delta symbol

In exothermic and endothermic reactions there are energy changes.

The diagram below shows the reaction profile for the reaction between zinc and copper sulfate solution.

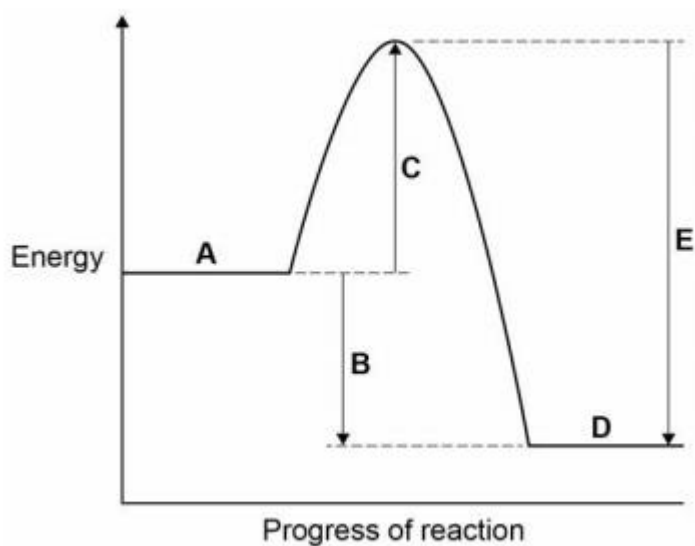

1. Which letter represents the products of the reaction?
2. Which letter represents the activation energy?
3. Complete the sentence using the words below.

The reaction is \_\_\_\_\_ and therefore  $\Delta H$  is \_\_\_\_\_

endothermic      exothermic      negative      positive

## Practical skills

The practical skills you learnt at GCSE will be further developed through the practicals you undertake at A-level. Your teacher will explain in more detail the requirements for practical work in Chemistry.

There is a practical handbook for Chemistry, which has lots of very useful information to support you in developing these important skills. You can download a copy [here](#):

### Activity 7 Electrolysis

Students were investigating if the time the current flows through an electrolyte affects the amount of copper deposited on the negative electrode.

#### Equipment:

Measuring cylinder  
Balance  
Two suitable electrodes eg carbon rods  
6V bulb and holder  
0.5 moles per  $\text{dm}^3$  copper sulfate solution  
Stopwatch  
Wires  
Power supply  
100  $\text{cm}^3$  beaker

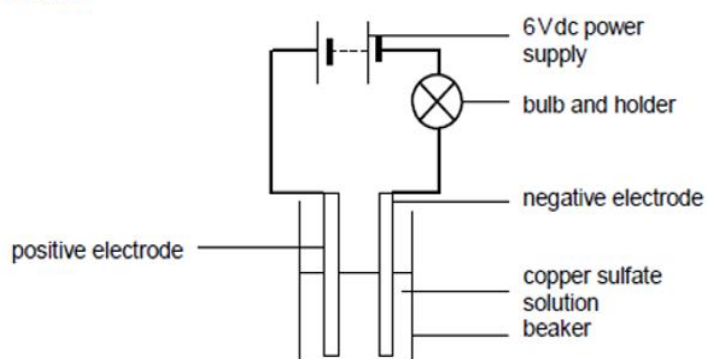

#### Method:

1. Measure 50  $\text{cm}^3$  of the copper sulfate solution into the beaker.
  2. Measure and record the mass of the negative electrode.
  3. Set up the circuit, setting the power pack at 6V dc.
  4. Turn on the power supply for the time you have been given, then turn the power pack off.
  5. Remove and carefully dry the negative electrode.
  6. Measure and record the mass of the negative electrode.
- 
1. Write a hypothesis for this investigation.
  2. What do you predict will be the result of this investigation?
  3. For this investigation, give
    - a. the independent variable
    - b. the dependent variable
    - c. a control variable.
  4. What is the difference between repeatable and reproducible results?

5. What would be the most likely resolution of the balance you use in a school lab?
6. How could you make the reading more precise?
7. Random errors cause readings to be spread about the true value.  
How could you reduce the effect of random errors and make the results more accurate?
8. The results the student recorded are given in the table.

Time / minutes	Increase in mass / g			Mean
2	0.62	0.64	0.45	
4	0.87	0.83	0.86	
6	0.99	1.02	0.97	
8	1.06	1.05	1.08	
10	1.10	1.12	1.10	

Calculate the mean increase in mass for each time measurement.

9. Plot a graph of your results.

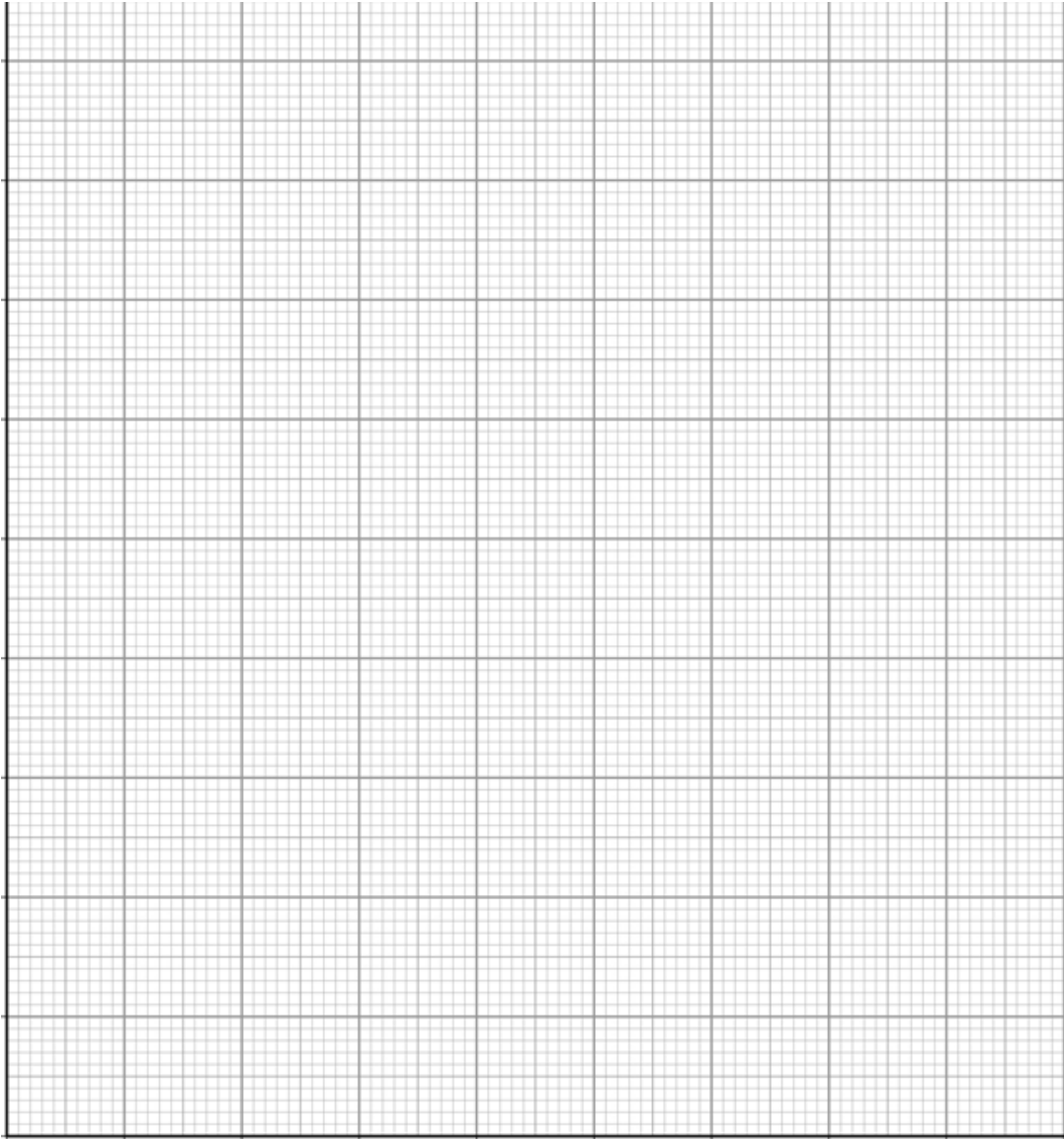

## Using maths skills

Throughout your A-level Chemistry course you will need to be able to use maths skills you have developed in your GCSE Chemistry and GCSE maths courses, such as using standard form, rounding correctly and quoting your answer to an appropriate number of significant figures.

### Activity 8 Using maths skills

1. Write the following numbers in standard form:

- a. 4000
- b. 1 000 000

2. Zinc oxide can be produced as nanoparticles.

A nanoparticle of zinc oxide is a cube of side 82nm.

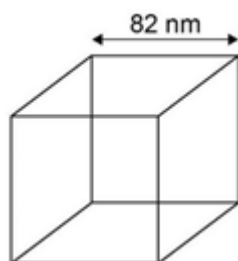

Calculate the surface area of a nanoparticle of zinc oxide. Give your answer in standard form

3. Express the following numbers to 3 significant figures:

- a. 57 658
- b. 0.045346

4. Toothpaste may contain sodium fluoride (NaF).

The concentration of sodium fluoride can be expressed in parts per million (ppm). 1 ppm represents a concentration of 1 mg in every 1 kg of toothpaste.

A 1.00 g sample of toothpaste was found to contain  $2.88 \times 10^{-5}$  mol of sodium fluoride.

Calculate the concentration of sodium fluoride, in ppm, for the sample of toothpaste.

Give your answer to 3 significant figures.

**Use the following information to help you**

To convert moles to grams use  $g = \text{moles} \times \text{relative formula mass}$

Relative formula mass of NaF = 42

### Using the periodic table

During your course you will need to become familiar with the periodic table of the elements, and be able to use information from the table to answer questions.

There is a copy of the periodic table that you will be given to use in your exams on the next page.



### Activity 9 Atoms

1. Give the atomic number of:
  - a. Osmium
  - b. Lead
  - c. Sodium
  - d. Chlorine
2. Give the relative atomic mass ( $A_r$ ) of:
  - a. Helium
  - b. Francium
  - c. Barium
  - d. Oxygen
3. What is the number of neutrons in each of the following elements?
  - a. Fluorine
  - b. Beryllium
  - c. Gold

### Activity 10 Formulae of common compounds

State the formulae of the following compounds:

1. Methane
2. Sulfuric acid
3. Potassium manganate (VII)
4. Water

## Activity 11 Ions and ionic compounds

The table below lists the formulae of some common ions.

Positive ions		Negative ions	
Name	Formula	Name	Formula
Aluminium	$\text{Al}^{3+}$	Bromide	$\text{Br}^-$
Ammonium	$\text{NH}_4^+$	Carbonate	$\text{CO}_3^{2-}$
Barium	$\text{Ba}^{2+}$	Chloride	$\text{Cl}^-$
Calcium	$\text{Ca}^{2+}$	Fluoride	$\text{F}^-$
Copper(II)	$\text{Cu}^{2+}$	Iodide	$\text{I}^-$
Hydrogen	$\text{H}^+$	Hydroxide	$\text{OH}^-$
Iron(II)	$\text{Fe}^{2+}$	Nitrate	$\text{NO}_3^-$
Iron(III)	$\text{Fe}^{3+}$	Oxide	$\text{O}_2^-$
Lead	$\text{Pb}^{2+}$	Sulfate	$\text{SO}_4^{2-}$
Lithium	$\text{Li}^+$	Sulfide	$\text{S}^{2-}$
Magnesium	$\text{Mg}^{2+}$		
Potassium	$\text{K}^+$		
Silver	$\text{Ag}^+$		
Sodium	$\text{Na}^+$		
Zinc	$\text{Zn}^{2+}$		

Use the table to state the formulae for the following ionic compounds.

1. Magnesium bromide
2. Barium oxide
3. Zinc chloride
4. Ammonium chloride
5. Ammonium carbonate
6. Aluminium bromide
7. Calcium nitrate
8. Iron (II) sulfate
9. Iron (III) sulfate

## Activity 12 Empirical formula

Use the periodic table on page 21 to help you answer these questions.

1. The smell of a pineapple is caused by ethyl butanoate.  
A sample is known to contain:

0.360 g of carbon  
0.060 g of hydrogen  
0.160 g of oxygen.

What is the empirical formula of ethyl butyrate?

2. What is the empirical formula of a compound containing:

0.479 g of titanium  
0.180 g of carbon  
0.730 g of oxygen

3. A 300g sample of a substance is analysed and found to contain only carbon, hydrogen and oxygen.  
The sample contains 145.9 g of carbon and 24.32 g of hydrogen.

What is the empirical formula of the compound?

4. Another 300 g sample is known to contain only carbon, hydrogen and oxygen.  
The percentage of carbon is found to be exactly the same as the percentage of oxygen.  
The percentage of hydrogen is known to be 5.99%.

What is the empirical formula of the compound?

### Activity 13 Balancing equations

1. Write balanced symbol equations for the following reactions.

You'll need to use the information on the previous pages to work out the formulae of the compounds.

Remember some of the elements may be diatomic molecules.

- Aluminium + oxygen  $\rightarrow$  aluminium oxide
- Methane + oxygen  $\rightarrow$  carbon dioxide + water
- Calcium carbonate + hydrochloric acid  $\rightarrow$  calcium chloride + water + carbon dioxide

2. Chalcopyrite is a sulfide mineral with formula  $\text{CuFeS}_2$ .

Chalcopyrite is the most important copper ore. It is a sulfide mineral, a member of iron (2+) sulfides and a copper sulfide.

Copper can be produced from rock that contains  $\text{CuFeS}_2$  in two stages.

Balance the equations for the two stages in this process.

**Hint: remember that sometimes fractions have to be used to balance equations.**

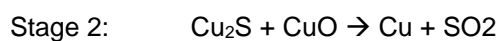
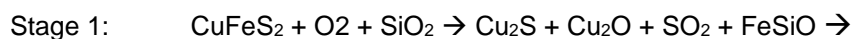

### Activity 14 Moles

The amount of a substance is measured in moles (the SI unit). The mass of one mole of a substance in grams is numerically equal to the relative formula mass of the substance. One mole of a substance contains the same number of the stated particles, atoms or ions as one mole of any other substance. The number of atoms, molecules or ions in a mole of a given substance is the Avogadro constant. The value of the Avogadro constant is

$6.02 \times 10^{23}$  per mole.

Complete the table. Use the periodic table on page 21 to help you.

Substance	Mass of substance in grams	Amount in moles	Number of particles
Helium			$18.12 \times 10^{23}$
Chlorine (Cl)	14.2		
Methane		4	
Sulfuric acid	4.905		

### Activity 15 Isotopes and calculating relative atomic mass

1. What is the relative atomic mass of bromine if the two isotopes  $^{79}\text{Br}$  and  $^{81}\text{Br}$  exist in equal amounts?

2. A sample of neon is made up of three isotopes:

$^{20}\text{Ne}$  accounts for 90.9%

$^{21}\text{Ne}$  accounts for 0.3%

$^{22}\text{Ne}$  accounts for 8.8%.

What is the relative atomic mass of neon?

Give your answer to 4 significant figures.

3. Copper's isotopes are  $^{63}\text{Cu}$  and  $^{65}\text{Cu}$ .

If the relative atomic mass of copper is 63.5, what are the relative abundances of these isotopes?

## Extended writing

The ability to write coherently in a logical, well-structured way is an essential skill to develop. At GCSE the 6-mark extended response questions are used so students can demonstrate this skill. At A-level you will still need to write precise answers using the correct scientific language.

The command word in a question, like at GCSE, is important as it gives you an indication of what to include in your answers. For example, 'explain' means you must give reasons why things are happening, not just give a description. A comparison needs advantages and disadvantages or points for and against.

### Activity 16 Types of bonding

Compare the similarities and differences between ionic, covalent and metallic bonding.